

Olfactory system: odorant detection and classification

Walter J Freeman

*Department of Molecular and Cell Biology, LSA 129
University of California, Berkeley CA 94720-3200 USA*

**The olfactory system: odor detection and classification.
Chapter in: *Frontiers in Biology, Volume 3. Intelligent Systems.*
Part II. *Brain Components as Elements of Intelligent Function.*
Amit D, Parisi G (eds.)
New York: Academic Press, 2001, Pages 509-526.**

**First published in Italian as:
"Il sistema olfattivo: rilevamento e classificazione degli odori"
Vol. III, Parte Seconda: *Organizzazioni di sistemi intelligenti*
Sezione III: *Parti del Cervello e Funzioni Intelligenti*, pp. 477-494.
Frontiere della Vita. Istituto della Enciclopedia Italiana
Fondata da Giovanni Treccani, Roma 1999**

Abbreviations

PON - Primary Olfactory Nerve, from receptors R to OB
OB - Olfactory Bulb, a part of the cerebral cortex
LOT - Lateral Olfactory Tract, from OB to olfactory cortex
AON - Anterior Olfactory Nucleus, between OB and PC
PC - Prepyriform Cortex, a main part of olfactory cortex
EC - Entorhinal Cortex, gateway to the hippocampus

R - Receptor cells, in the mucosa lining the nose
P - Periglomerular cells, in the outer OB
M - Mitral cells, excitatory projection cells in OB
T - Tufted cells, excitatory association cells in OB
G - Granule cells, inhibitory in OB
A - Excitatory pyramidal cells in PC
B - Inhibitory interneurons in PC
E - Excitatory pyramidal cells in AON
I - Inhibitory interneurons in AON
LMF - Local Mean Field
ODE - Ordinary Differential Equation
PSP - PostSynaptic Potential; EPSP - Excitatory, IPSP - Inhibitory
EEG - Electroencephalogram - oscillatory potentials from scalp or brain

••Paragraph summaries are identified **, at the end of the pertinent paragraph.**

Abstract

The architecture and dynamics of the olfactory system have evolved to solve the major problems in olfactory information processing. The problems stem from the requirement for an immense number of receptor cells in the nose needed to capture odorant molecules in low concentration and unpredictable variety. They include normalization and dynamic range compression of input; generalization of output over equivalent receptor cells; selective amplification of foreground odorants against complex chemical backgrounds; compression and storage of information that defines classes of behaviorally relevant odors; fast, unbiased access to any class on any inhalation in time frames on the order of 0.1 sec; construction of a signal for transmission into the brain to denote the presence or absence of an identified odorant; enhancement of the signal:noise ratio upon central transmission; and modification and up-dating of the selectivity to form new classes by habituation and associative learning. Operations that solve these problems are simulated in a model of olfaction derived from experimental recordings and expressed in coupled nonlinear differential equations. The model is evaluated by simulation of spatiotemporal olfactory electroencephalographic (EEG) patterns with chaotic dynamics, and by devising neural network models for pattern classification that operate in noisy, high-dimensional, rapidly time-varying environments. Reasons are given to view olfaction as giving a guide to mechanisms of perception in all sensory systems.

1. Introduction.

All animals including ourselves are embedded in a world of chemicals that provide the odors we use to eat, find mates, and avoid dangers. Our most intimate contacts concern our daily bread, with whom we sleep, the health of our bodies, and the physical states of those we love and hate. The dependence of humans on olfaction for survival is not so vital in our civilized world as it is for wild animals and was for our ancestors foraging in Africa, because our food comes in safe packages, and our air is sanitized. Yet brains evolved around olfaction, and the other sensory systems use elaborations of its basic algorithms. How does the olfactory system work? This review lists the tasks that are carried out by the olfactory system with its three main components (Figure 1): the layer of receptors in the nose (R), the bulb (OB), and the prepyriform cortex (PC). It describes the nature of each problem, the operation by which it is solved, and a dynamical model consisting of coupled nonlinear ordinary differential equations (ODEs) that simulates the operations. The roles are described of associative learning and habituation in the formation of classes of discriminated odors, and a role is assigned to the entorhinal cortex (EC) in the limbic system for centrifugal control of the access by the OB to any particular class that is selected by the forebrain in the process of attention.

The model embodies a theory for dynamic pattern classification of odors, that is built on an extensive anatomical and physiological data base from the central olfactory system, and that explains some of the psychophysical properties of olfaction (Freeman 1975, 1992; Skarda and Freeman 1987). The model may also account for the integrative neurobiology of vision, audition, and somesthesia, particularly the binding problem, for three reasons. First, in the evolution of vertebrate forebrains olfaction preceded all other senses, and set the direction of development of algorithms for perception. Second, all sensory systems converge to the EC, and they must develop and share a common mode of function in order to support the emergence of

multisensory perceptions. Third, the spatiotemporal patterns of EEGs from the sensory neocortices show the same changes with learning and have the same spectral and statistical properties as the olfactory EEGs (Barrie, Freeman and Lenhart 1996). Serious students of the evolution of brains have long believed that the nature of brain function in consciousness and intentionality will not be solved until olfaction is clearly understood (Herrick 1948; Freeman 1995).

••Olfaction was pre-eminent in evolution of vertebrate brains in goal-directed behavior.**

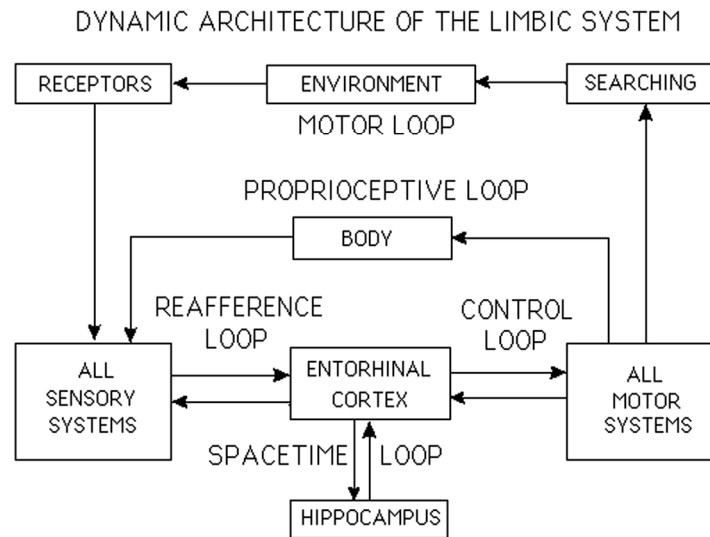

Figure 1. The central core of the mammalian forebrain is formed by the limbic system, including the entorhinal cortex (EC), which is the main source of input to the hippocampus and its principle target. All sensory systems transmit to the EC and receive corollary discharge from it in the aspect of motor control known as preafferece (Kay, Freeman and Lancaster 1996). The box outlines the three main parts of the central olfactory system.

1.1. Olfactory transduction to form spatial patterns of nerve impulses.

The olfactory system operates between the transduction of odorant chemicals into action potentials and the limbic mechanisms that organize and direct intentional behavior and require olfactory information (Sullivan and Dryer 1996). The main outlines of chemotransduction are fairly well understood. The outward ends of the olfactory receptor cells maintain threads called cilia, which are studded with specialized protein molecules. An odorant molecule combines with a receptor molecule the way a key fits in a lock and turns it, which triggers a cascade of second messengers and releases electrical current. The current on crossing the membrane of a receptor cell axon triggers a train of action potentials. The receptor cells are embedded in a sheet lining the nasal cavity, so that each odorant activates a subset of the receptor cells and initiates a spatial pattern of action potentials. The pattern is carried into the brain by an array of axons constituting the primary olfactory nerve (PON). Owing to a degree of topographic order in the PON, another spatial pattern of activity is initiated in the outer layer of the olfactory bulb (OB). There are at

least 1,000 types of receptor molecules in the cilia, and the cells carrying the molecules are unevenly distributed in the mucosa in coarse groups, so that different odors elicit different spatial patterns of neural activity in the mucosa. Discrimination among odors is a problem of spatial pattern classification.

Records of the bursts of impulses from stimulation of single receptors show that each neuron is broadly tuned to respond to a range of odors. Even so, each odorant injects a distinctive spatial pattern of activity into the outer layer of the OB, where PON input is spatially coarse-grained into nests of synaptic activity called glomeruli. In these peripheral respects olfactory functions are essentially the same as those in the visual, auditory, somatic and gustatory systems, in all of which the end result is the transduction of a physicochemical stimulus by a sheet of receptors to a time-varying, two dimensional spatial pattern of action potentials that is injected into the cortex.

****Odors are transduced by receptor neurons to spatial patterns of OB action potentials.****

Unlike receptor cells that are quiet until stimulated, central neurons are continuously active with background firing of impulses that occur seemingly at random, and with modest increases or decreases in mean firing rates when they are stimulated. The tuning of the central neurons is just as broad as it is for receptors, and the spatial patterns of OB neural activity lack invariance with respect to particular odors (Freeman 1991). This report deals mainly with problems that are solved within the duration of a single inhalation or sniff. It does not address serial sampling as in tasks of odorant tracking or hierarchical classification, but only the mechanisms for detection and classification of an odorant on a single trial, as demonstrated by the correct performance of a conditioned reflex to an odorant conditioned stimulus.

1.2. The limbic context of olfactory function.

All the sensory systems feed into and are largely controlled by the brain, and these aspects must be touched on in a review of olfaction, even though more central aspects of olfaction are less well understood. One of two main sources of control are the neuroamine and neuropeptide modulatory nuclei in the hypothalamus and brainstem, which project diffusely to all parts of the forebrain, and which regulate states of arousal and motivation in reward and pain, as well as the processes of learning and memory. The other source of control is the limbic system, which is centered in the hippocampus, and which is the focus of goal-orientation of behavior in space and the organization of memory over time (Figure 1). In mammals the main source of hippocampal input is the EC. It receives its input from all sensory cortices, and it is the chief target of hippocampal output. Axons from limbic structures descend to the striatum and amygdaloid nucleus, which serve as control systems of the skeletal muscles; to the septum for autonomic and neuroendocrine support of actions; and to the neuromodulatory nuclei for regulation of motivation and emotional states. The EC also transmits back to all the sensory cortices from which it receives its input.

****Responses to odorant stimuli are shaped by forebrain controls of the olfactory system.****

A hypothesis of olfactory function (Freeman 1995; Kay, Freeman and Lancaster 1996) is that convergent sensory input is used to update a central active state covering the last few seconds by the entorhinal-hippocampal time loop, and that motor commands emitted to elicit intentional behavior through the motor loop such as sniffing are accompanied by corollary discharges called "preafferent" messages through a preference loop. These messages sensitize the sensory cortices to respond selectively to the expected consequences of the intended actions of exploration. By this hypothesis, sights, sounds, and touches are predicted to influence the function of the OB in ways that are to be determined. Olfactory classification is not a passive tree search. It is an active, goal-directed exploration of a continuously varying and infinitely complex chemical environment.

1.3. The central topology of olfaction.

The 2-dimensional sheet of receptors R sends its axons directly into the OB (Figure 2). The bulbar neurons onto which the R neurons synapse send their axons by way of the lateral olfactory tract (LOT) to the PC, which according to Herrick (1948) is a motor cortex. The OB and PC both send axons into the EC, which sends preafferent feedback to both the OB and PC by way of the medial olfactory tract (MOT) as the anatomical substrate for olfactory attention. The limbic system gates the input to the receptors by its control of goal-oriented sniffing (Freeman 1995). There are two subsidiary control elements in the olfactory system. One element is the periglomerular cells (P) in the outer layer of the OB, where it serves to preprocess receptor input to the OB. The other element is the anterior olfactory nucleus (AON), which relays centrifugal controls from neurons in the limbic system, basal forebrain, and brain stem in respect to arousal, motivation, attention, and reinforcement learning (Gray, Freeman and Skinner 1986; Shipley and Ennis 1996).

Control nodes in the centripetal flow of olfactory activity are the P cells and the AON.

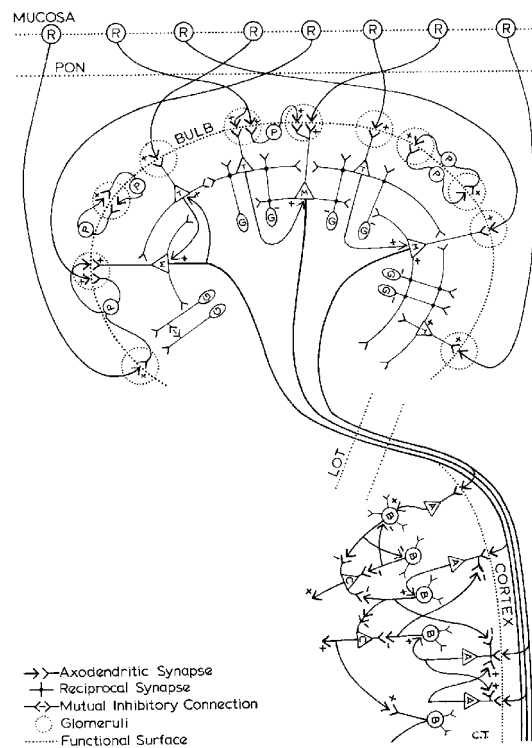

Figure 2. The main cell types and connections are shown for the olfactory bulb (OB) and the anterior olfactory nucleus (AON) and prepyriform cortex (PC) (combined as "cortex"), to which it transmits by the lateral olfactory tract (LOT). Receptors (R) axons excite periglomerular (P), mitral (M) and tufted (T) cells, which excite the inhibitory granule (G) cells. Mitral axons end on pyramidal cells (A), which excite stellate cells (B) and are inhibited by them in a negative feedback loop. Not shown is the medial olfactory tract (MOT) which transmits from the deep pyramidal cells (C) in the cortex to the granule cells (G) in the OB. From Freeman (1972b)

Within the glomeruli the R axons synapse onto the dendrites of P cells and the apical dendrites of the main set of excitatory neurons in the OB, the mitral (M) cells. The M cells excite inhibitory interneurons called granule (G) cells, which act onto the M cells by negative feedback. The M cells send their axons into the LOT, where they form synapses on the other dendrites of superficial pyramidal cells in the AON and PC. The M axons excite the pyramidal cells (E and A), which in turn form excitatory synapses onto the inhibitory granule cells (I and B) in the AON and PC. The inhibitory cells provide negative feedback to the pyramidal cells and forward inhibition to the deep pyramidal cells (C), which send their axons in the MOT to the G cells in the OB on the same side (ipsilateral) and on the other side (contralateral) of the brain (Heimer 1968) for feedback normalization of the OB outputs. The deep pyramidal cells also send their axons into the EC, the amygdala, septum, and olfactory striatum, for relay into the brain stem and spinal cord.

Each of the cells in the populations interacts with its own kind by positive feedback. Mutual excitation among neurons serves in the formation of nerve cell assemblies and in models of

associative memory, together with lateral inhibition giving contrast enhancement in classification of odors (Shepherd 1994). Anatomical evidence for mutual excitation was provided by Ramón y Cajal in his studies of collateral axons in the internal and external plexiform layers of the OB from the mitral cells (M, the OB projection neurons) and tufted cells (T, the associational neurons in the OB) to each other as the basis for his theory of "avalanche conduction", and of axon collaterals interconnecting the pyramidal cells (A) in the inner two thirds of the molecular layer of the prepyriform cortex (Heimer 1968). Physiological evidence has come from measurements of the firing probabilities of M, T, and A cells on electrical impulse stimulation of the PON or LOT. The mutual excitation is shown by the high probability of discharge after they have fired once in response to the input, at the time that they are exciting the inhibitory neurons but before they are inhibited by the feedback (Freeman 1975). Mutual inhibition, which is also a form of positive feedback. An anatomical basis for it may be the GABAergic short axon cells that interconnect the granule (G) cells in the OB, and the axons between the inhibitory interneurons in the AON and PC (I and B). Physiological evidence takes the form of modeling the dynamics of the OB and PC (Freeman 1975) under parametric and pharmacological manipulations of the various neurotransmitters involved (Shipley and Ennis 1996).

Neural populations sustain internal interactions by mutual excitation, mutual inhibition, and negative feedback that gives oscillations.

2. Operations on sensory input by the central olfactory system.

2.1. Dynamic Range Compression.

The olfactory mucosa provides a high probability of capture of odorant molecules in low concentration by maintaining a vast number of receptors, on the order of 10^7 to 10^8 in each nostril. Psychophysical studies in trained subjects indicate that only a few molecules may suffice at threshold for odorant detection, activating only a few receptors, though identification can also occur at high concentration activating thousands of receptor cells. Each glomerulus receives on the order of 10^4 receptor axons, so that the effective dynamic range of input may approach 10^4 . Yet the range of OB dynamics, as shown by testing with electrical stimulation of the primary olfactory nerve is less than 4 (Freeman 1975). Hence a neural mechanism for dynamic range compression and logarithmic scaling of input amplitudes is required, as it is in all other sensory systems, because identification occurs over several log units of odorant concentration. The mechanism to perform these operations must use the strength of the periglomerular local mean field (LMF), which is the output of an OB neuron population, in order to re-scale the OB response to the input (see equation (5) in Section 4.2.).

Odorant detection requires logarithmic scaling, normalization, and temporal integration.

2.2. Generalization over equivalent sensory inputs.

While each receptor cell responds to many odors and no two profiles are identical, those that respond to the same odorant over a large number of sniffs form a class. The size of that class is not known for any odorant, but it might range between 0.1% and 1.0% of the total number of receptor cells, so a typical class of receptors may have 10^5 to 10^6 cells. At low concentrations

only a few cells in a class are excited, for example $10^1 - 10^3$. They are selected randomly, due to turbulence in airflow over the turbinate bones in the nose. The OB must solve the problem of generalization over equivalent receptors, because no two spatial patterns of input with inhalation are likely ever to be identical, and identification is repeatedly done on spatial patterns of input that have never previously been received. As will be described, the generalization occurs when the microscopic receptor input initiates the construction of a macroscopic bulbar activity pattern. The problem for the OB is to construct patterns that are sufficiently similar over multiple inhalations of the same odorant, that they can be clearly distinguished by the PC and the limbic system from the spatial patterns that are constructed for other odors, including the background odorant complex, which contains undefined and unmeasurable, time-varying components (see also Section 5.6).

****A mechanism is required for generalization across equivalent odorant receptor neurons.****

2.3 Input Selectivity by associative learning and habituation.

The mucosa responds to whatever is given to it, but the OB is highly selective, most spectacularly so in responding to low concentrations of a target odorant, when it is mixed with numberless other unknown odors, and when both the foreground and the background odors are nonstationary, owing to aging, dilution, and the effects of light, heat and chemical mixing. This implies selective amplification of the input from one odorant and the attenuation of responses to all other inputs, as well as the continual modification of OB sensitivity, by neural mechanisms of motivation, associative learning and habituation. In a review of psychophysical studies Rabin and Cain at Yale have shown that animals were able to discriminate less than 16 odors at a time, so that seldom used classes of odors must be overlaid or suppressed, if greater than that number of new classes is formed to meet new environmental conditions. They also conclude that humans such as perfumers, enologists and tea tasters use language to develop an indefinitely large repertoire of odorant classes. Hence the output of the PC must provide for rapid, coarse-grained classification to support immediate action, as in pursuit of prey and avoidance of predators, but it must also provide the large amount of information that is needed for higher order information processing by the forebrain in humans.

****Selective amplification is set by Hebbian learning and habituation.****

2.4 Signal Construction and Signal:Noise Enhancement.

The versatility of the OB indicates that it has a large store of information used to establish and exercise selective sensitivity, that this store is highly compressed in the OB, and that each available specific sensitivity may be immediately accessed on any one sniff. The identification can be very rapid, within the duration of a single sniff of less than 200 msec. Since transduction and primary olfactory nerve transmission require about 100 msec, the time for odorant classification should not exceed 100 msec. The system must return promptly to its basal state to process repeated new samples, as in tracking or in performing difficult odorant discriminations. Synaptic modification occurs in the OB and PC during associative learning (Freeman 1975,

1995; Gray et al. 1986; Bressler 1988). Responses to odors in the OB take the form not of retrieval, but of fresh construction by nonlinear dynamics. The constructs are shaped by synaptic modifications from past experience, and by preafferent signals from the limbic system. Synapses in the olfactory system are modified during learning, not to store memory traces of odors that are to be recalled and matched with new odorant patterns, but to guide the dynamic construction of OB activity patterns as a basis for classification following identification. The problem is to describe and model those neural mechanisms that must exist in the central olfactory system, by which the signals of the OB are constructed, and the ratio of signal to noise of the bulbar output to the PC is defined and enhanced.

****Odorant identification is by construction, not by storage, recall, and pattern matching.****

3. Derivation of equations for modeling olfactory neural activity

3.1 State variables: microscopic pulses and macroscopic waves

Neurons in the central olfactory system maintain activity that is observable in two modes (Figure 3): waves of dendritic current (reflected in EEGs in macroelectrode recordings) and pulses from axons (observed as action potentials or "units" in microelectrode recordings). Typically the neurons receive pulses onto their dendrites at synapses, which act as chemical batteries to generate time-varying synaptic ionic current. The current is carried by the dendrites to the cell body from which the axon emerges, and the sum of synaptic currents is expressed as a transmembrane potential difference at the initial segment of the axon near the site of anatomical convergence of the dendritic branches. At the trigger zone the sum is re-expressed in the modulation of the pulse probability of the neuron. Excitatory current flowing outwardly increases the probability of firing, whereas inhibitory current flowing inwardly decreases it. The pulse output is transmitted with propagation delay and with amplification by axonal branching to synapses of other neurons.

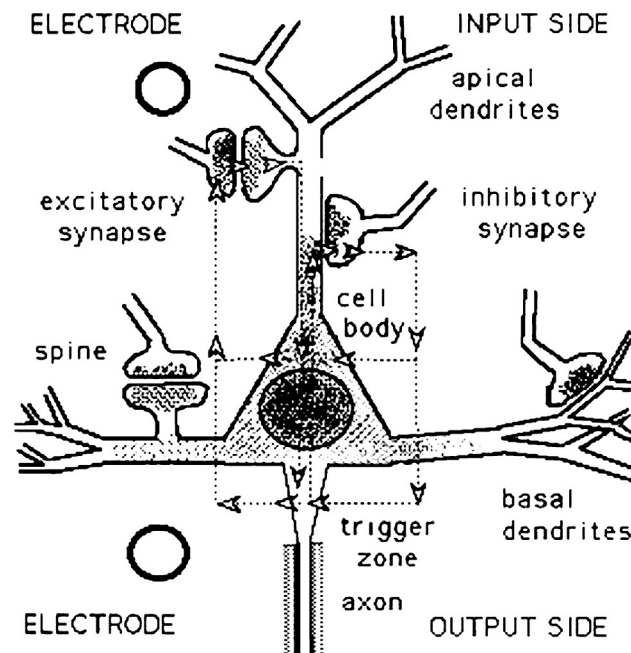

Figure 3. Synaptic current flows in closed loops. The same current gives a postsynaptic potential (PSP) detected with an intracellular electrode and an electroencephalographic (EEG) wave when recorded extracellularly. Excitatory synapses cause EPSPs and outflow at the trigger zone; inhibitory synapses cause IPSPs and inflow. PSPs and pulses (action potentials) are microscopic observables. The sum of extracellular currents of neighboring neurons gives a macroscopic variable, the local mean field (LMF) of the population.

The synaptic currents always flow in closed loops from synapse to trigger zone and back again, in one direction inside the neuron and in the other direction outside the dendrites. The same current that controls the pulse probability of single neurons is added in the extracellular space to the currents of other active neurons in the neighborhood, and it gives rise to an extracellular potential difference that is manifested in the EEG. Instead of being related to the probability of firing of any single neuron, the sum of the extracellular dendritic potentials is related to the relative mean pulse frequency of the contributing neurons. When it is defined over a local spatial neighborhood, the EEG is related to the pulse density, p_j , of the j -th neural population. Because the contributing neurons also interact with each other by excitatory synapses to and from their neighbors, the EEG manifests the local mean field (LMF) of activity density for the population, v_j . This is a macroscopic variable in contrast with the train of action potentials and the PSP of a single neuron, which are microscopic state variables (Freeman 1972b, 1975, 1992). Because the term LMF is borrowed from thermodynamics, it applies only to those ensembles in which interactions determine the macroscopic variable. For example, the currents generated by axons giving a compound action potential form a "sum" that does not constitute a "mean", because the non-interactive action potentials disperse instead of converging.

••Coexisting microscopic and macroscopic neural activity patterns shape each other.**

Because each bulbar and cortical neuron receives from several thousand other neurons, the impact of any one synapse is small, on the order of 10 microvolts or about 1% of the amount of excitation that is required to bring a neuron to threshold, so that even in the absence of inhibitory input, the convergence of multiple excitatory inputs is required. Due to their excitatory synaptic interactions, the neurons in local neighborhoods on the average are subject to the same or similar inputs. They all contribute to the same output, but with random rotation among them to express the pulse density. In other words, the neurons in a local population are time-multiplexing the signal of the population. This keeps the microscopic density of activity at a low level and stabilizes the extracellular ionic concentrations. Randomized time-multiplexing among the hundreds or thousands of neurons comprising a neighborhood makes it difficult to detect a population LMF from pulse recordings, and gives extraordinary value to the dendritic fields of the EEGs.

****Dendrites integrate in the wave mode; axons transmit in the pulse mode.****

3.2. The sigmoid curve and its derivative, the nonlinear gain.

The operations of dendritic integration in the wave mode and axonal transmission in the pulse mode occur in small-signal, near-linear ranges, so that they can be described by means of linear ODEs. In experiments in behaving animals in which the range of amplitudes of evoked or induced neuroelectrical activity does not exceed the peak amplitude of the background EEG, the pulse-to-wave conversion at synapses is linear and time-invariant over the short term (seconds to minutes), so the strength of action at each synapse is expressed by a fixed coefficient that can be changed in the long term by associative learning and habituation. The operation of wave-to-pulse conversion at trigger zones is nonlinear, owing to the threshold at low firing rates and the relative refractory period at high firing rates. Whereas the description of the dynamics of single neurons at the microscopic level is by four 1st order time-varying, nonlinear Hodgkin-Huxley equations, the description of a population of neurons at the macroscopic level is simpler. The output of the population is a pulse density, not a pulse train, and the microscopic pulse trains are uncorrelated and nearly random, so the nonlinear operator of the population is time-invariant and continuous. It conforms to an asymmetric sigmoid function, for which the first derivative is an asymmetric bell-shaped curve, the nonlinear gain (Figure 4).

****Sigmoid curve from microscopic thresholds and refractory periods at the macroscopic level.****

The sigmoid nonlinearity for a population is measured by calculating the pulse probability of a single neuron or a local neuron group conditional on the amplitude of its EEG. An equation has been derived by a generalization from the Hodgkin-Huxley model to neural populations, and fitted to the experimental conditional pulse probability functions (Figure 4). The resting level, steepness and maximal asymptote are determined solely by Q_m . These quantities increase together with increasing motivation and decrease sleep or anesthesia, ultimately to zero when all activity has been suppressed by a strong anesthetic.

The most remarkable feature of this sigmoid curve in the OB, PC, and EC is that the maximal slope is displaced to the excitatory side of the resting level. An excitatory input to the populations raises the activity level of its neurons, and also increases their sensitivity to input

from each other, so that they interact more strongly. The measure of this sensitization is the slope of the sigmoid curve, that gives the nonlinear forward gain within each population of neurons. The square of this curve gives the feedback gain. The R input increases the activity of both M and G cells, and their regenerative feedback interaction. The sensitization is responsible for the burst of oscillation that accompanies the respiratory wave of OB response to R input with each inhalation, because above a certain threshold, runaway excitation among the excitatory cells destabilizes the whole OB.

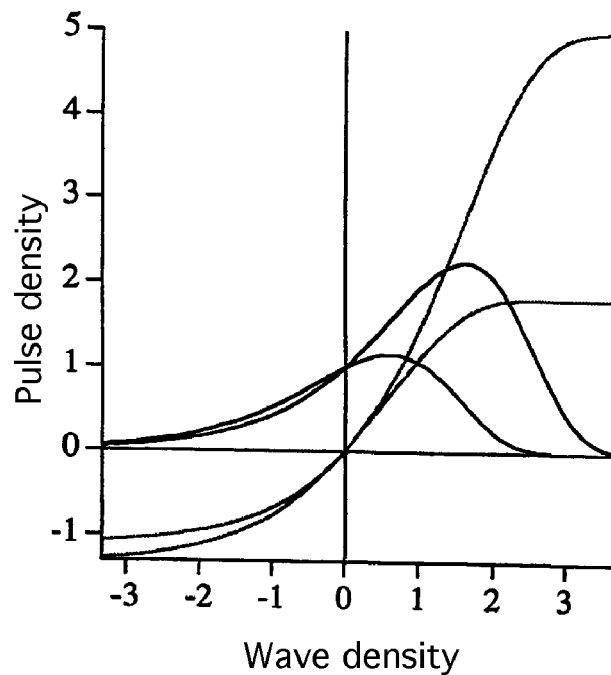

Figure 4. The nonlinear relation is shown for conversion of dendritic wave amplitude to axonal pulse density. The triangles show the background stable point (mean pulse density) for two values of the maximal asymptote: $Q_m = 3.5$ and 5 . Each sigmoidal function for the j -th population, $p_j = G_j(v_j)$, is computed (light curves) from equation (1).

$$p = p_0 (1 + \{1 - \exp[-(e^v - 1)/Q_m]\}). \quad (1)$$

The nonlinear gain G_j of the j -th population (dark curves) is given by the derivative,

$$dp/dv = u_0 \exp[v - (e^v - 1)/Q_m]. \quad (2)$$

The positive exponential reflects the voltage-dependent G_{Na} , showing that near p_0 the neurons in the population usually are below threshold and near equilibrium. The slope of the sigmoid increases with arousal and is measured by Q_m .

The entire bulb jumps from a low energy background state to a high energy transmitting state, with a new spatial pattern of activity. The slope of the sigmoid (magnitude of the nonlinear gain) is also dependent on the degree of motivation or arousal as in hunger or thirst, so that bursts do

not occur in animals fed to satiety, and burst amplitude increases monotonically with the duration of food deprivation (Freeman 1975).

The asymmetry of the sigmoid function means that the OB is destabilized by input.

3.3. The open loop impulse response.

The impulse response of the single neuron is observed in the form of an intracellularly recorded postsynaptic potential (PSP). It has a rising segment with a short time constant due to synaptic and dendritic cable delays, and a decaying segment due to the passive resistive-capacitive electrical properties of the membrane. The same wave form is observed by extracellular recording from ensembles of neurons (Figure 5), in which the synaptic interactions are suppressed by anesthesia to give the open loop state (Freeman 1975). The wave form approximates the solution of a linear 2nd order ODE with impulse input. It describes the integrative operation of a population of neurons F_j (Figure 5) between a synaptic gain coefficient k_{ij} and a sigmoid curve G_j (Figure 4). All of the gain coefficients are fixed for the duration of each sniff, but some of them denoted as "modifiable" are subject between sniffs to increase or decrease in the processes of dynamic range compression, signal normalization, motivation, habituation, and associative learning.

The characteristic frequencies of OB and PC oscillation are set by the passive membrane time constants of their neurons.

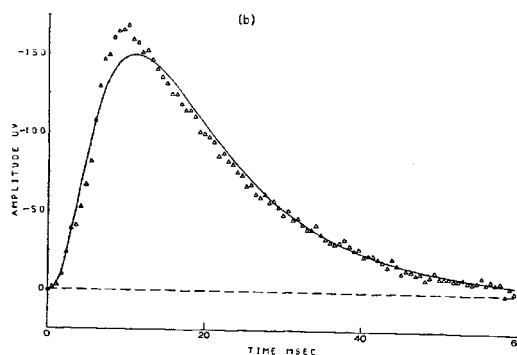
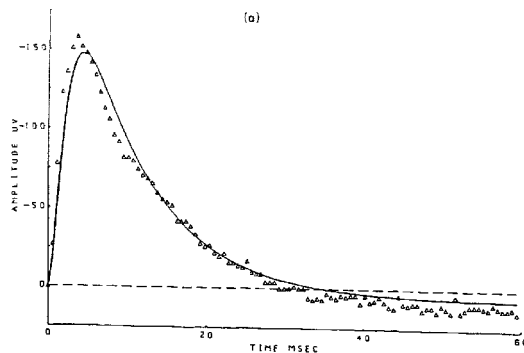

Figure 5. The open loop impulse responses under deep anesthesia are shown for the G cells in the OB with direct input from (a) electrical stimulation of the LOT and (b) with input through the M cells on stimulation of the PON. The rising phase in (b) is determined by the M cells. Paired-shock testing of superposition shows that the responses are in a small signal linear range, so the data points are fitted with the sum of linear basis functions (exponential terms). A sufficient approximation for the transfer function of M_i and G_i populations is a linear 2nd order for the i -th population:

$$F_i = d^2v_i/dt^2 + (a + b) dv_i/dt + ab v_i = \delta_j(t), \quad (3)$$

where $a = 220/\text{sec}$ (4.6 msec) is the passive decay rate, $b = 720/\text{sec}$ (1.4 msec) is the dendritic delay rate, and $\delta_j(t)$ is the impulse approximating an electrical stimulus to the j -th axonal input. From Freeman (1972a).

3.4. Negative feedback and closed loop oscillations in OB, AON, and PC.

Neural oscillators are composed of large numbers of excitatory (M, E, or A) and inhibitory (G, I, or B) neurons, and that the oscillations are due to the synaptic connections between them. The excitatory neurons form the forward limb in each loop, receive the input, and gives the output of each oscillator. The inhibitory interneurons form the feedback limb. Activity in each limb is observed in either the pulse mode or in the wave mode in the OB, AON and PC. The characteristic frequency of each oscillator is determined by the mean time constants of the neurons and their forward gains in each limb. The time constants are determined by fitting the sums of exponential curves to the open loop impulse responses (Freeman 1972b, 1975). These curves contain the passive membrane time constant (4.55 msec) and a rational approximation for the cable delay of the dendrites (1.39 msec). The forward and loop gains are calculated from the closed loop rate constants derived by measuring the frequencies and decay rates of averaged evoked potentials and poststimulus time histograms from the OB, AON and PC (Freeman 1975).

EEG oscillations in OB and PC are due to negative feedback between excitatory and inhibitory neuron populations.

Measurement of the passive membrane time constants for the excitatory and inhibitory neurons in the OB shows that they have the same value. The time constants of the excitatory limb of the AON and PC also have been shown to be equal to those of the OB within the limits of experimental error (Freeman 1975). These several open loop time constants are fixed during recovery from anesthesia to the normal closed loop state.

Each cycle of an oscillation consists of four steps in two passages around the loop: excitation of E; excitation of I; inhibition of E; and inhibition of I, leading then to disinhibition and thereby re-excitation of E. Roughly speaking, four times the sum of delays gives 24 msec, which is about 40 Hz and characteristic of the central olfactory system. However, the frequency varies widely around this value (35 - 100 Hz, the gamma range), in part because it is dependent on the amplitude of the oscillation, due to the nonlinearity of conversion of wave activity to pulses at trigger zones (Freeman 1975), and in larger part because the excitatory and inhibitory

populations are interacting with each other in positive feedback loops, that are strong determinants of the characteristic frequency of the negative feedback loop.

Frequencies of activity are measured in the wave mode from the autocorrelation of the EEGs and from the impulse responses of the OB and PC to electrical stimulation of the PON or the LOT by fitting curves to the averaged evoked potentials. The frequencies are also measured as pulse probabilities by calculating the time-lagged conditional probability of firing conditional on EEG amplitude (Freeman, 1975), and from the impulse responses by fitting curves to the poststimulus time histograms of action potentials. These impulse responses have the forms of damped sine waves. Measurements of simultaneous outputs of the excitatory neurons and of the inhibitory neurons show that the sine wave from the two populations has the same frequency and decay rate, but the phase difference between the outputs of the two limbs is near 90° , independently of the value of the shared frequency of oscillation, whether the changes in frequency occur at random or are induced by surgical and pharmacological manipulations. These phase differences imply that the time constants of the inhibitory limbs in the AON and PC are equal to those of the excitatory limbs, and that the oscillations are due to macroscopic interactions of intrinsically nonoscillatory neurons.

Negative feedback is shown by a quarter cycle phase lag of I waves behind E waves.

3.5. Self-sustaining chaotic activity in olfactory EEGs and models.

A schematic diagram is shown in Figure 6 for a network of neural populations constituting the olfactory system. Each light circle or node represents a population of excitatory (P, M, E, A, C) or inhibitory (G, I, B) neurons. The dark circles represent axonal tracts in the lateral (LOT) and medial (MOT) olfactory tracts that contribute delay and dispersion, which are represented by linear 2nd order ODEs constituting low pass filters. The time constants of the ODEs are evaluated by measurement of open loop impulse responses (Figure 5).

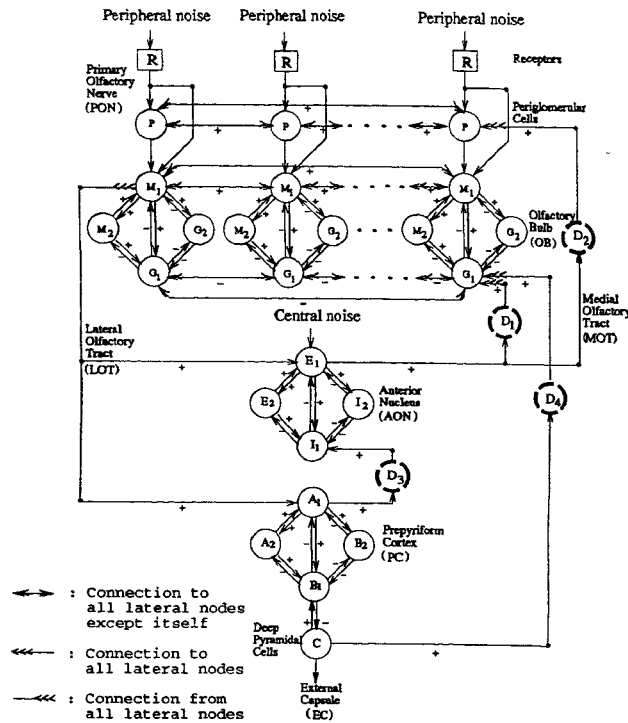

Figure 6. A flow diagram is constructed from anatomical connection data and used to specify the inputs and outputs of a set of coupled ODEs. Each node, F_i , sums inputs from all other nodes, v_j , after the sigmoid conversion, G , and the synaptic weights, k_{ij} , $i \neq j$ (no neuron acts synaptically onto itself):

$$F_i = \sum k_{ij} G [v_j] + n_j , \tag{4}$$

where n_j is input, including Gaussian noise that is required to stabilize chaotic attractors in the model and to simulate receptor input. The OB layer is modeled by 64 oscillators, each containing interactive M sets and G sets, and its own P set. The L1 to L4 operators model axonal tract dispersion and delay with linear 2nd order low pass filters. This constitutes the KIII model of the olfactory system. From Yao et al. (1990)

The k_{ij} 's for the connections between the pairs of nodes within the OB, AON, and PC are evaluated by solving the equations for specified impulse input and boundary conditions and adjusting them so that the solutions fit the electrophysiological responses of the olfactory system for that input. This is the only way to estimate the strengths of the synaptic links in neural feedback loops. The k_{ij} 's between the R, OB, AON, and PC are modified until the model achieves a stable steady state and 'spontaneously' generates output that has the appearance, spectra, and statistical properties of the EEGs from the several structures (Figure 7).

****Synaptic 'gains' determine the EEG characteristic frequencies in OB, AON, and PC.****

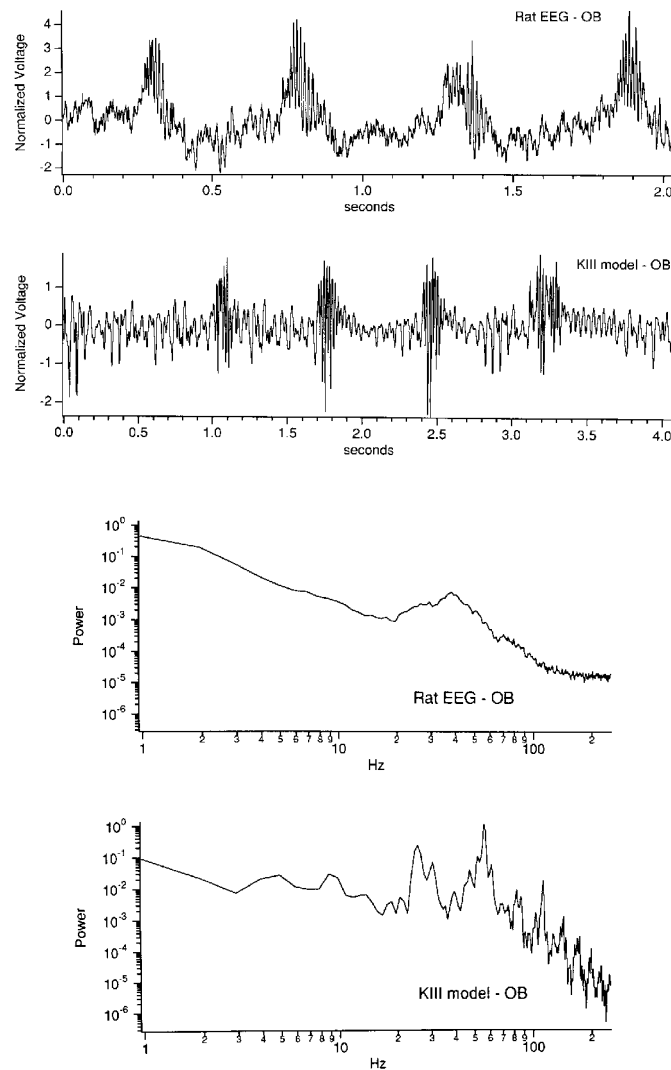

Figure 7. Observed EEG from the OB of a waking rat and simulation of G output by the KIII model. Upper frames: Time series. Lower frames: Spectra. From Kay et al. (1995)

The flow diagram in Figure 6 indicates an expansion of the OB into 64 simulated glomeruli and P populations feeding to 64 interconnected M and G populations, all receiving delayed and distributed feedback from the AON and PC. It has 730 globally interconnected 1st order ODEs. A system of this complexity, after it has been given a brief perturbation and is allowed to follow its own trajectory, goes through a transient period of oscillatory activity and then settles into a stable state. The stability of the steady state is determined by perturbing it with transient inputs and determining whether it goes back to the same state. If it returns to the same state, it is said to have an attractor. The range of input perturbation for which the system returns to that state is called the basin of attraction. If the system fails to return to that state, it is said to have undergone a state transition, and to have entered into the basin of another attractor with a different spatiotemporal pattern of activity. There are three main classes of stable state, which are characterized by the spatiotemporal pattern that the system adopts. The simplest is a nonoscillatory steady state that manifests a point attractor. This state is induced by deep

anesthesia, which suppresses background EEG and impulse activity, opening the loops (Figure 5). When the system enters into periodic oscillation at one or more frequencies, it is said to be governed by a limit cycle attractor. This state can only be observed after the OB and PC have been separated from each other surgically or pharmacologically (Freeman 1975). The third state is characterized by aperiodic, broad spectrum oscillations, which manifest a strange or chaotic attractor, which is characterized by its aperiodic output.

****An attractor is a stable state, accessed through a basin, a specified range of input.****

An example in Figure 7 compares the EEG from the OB of a rat with the output of the G cells in the model. The spectra of the two traces in Figure 7 show broad spectra that tend to conform to "1/f" (log power decreases linearly with log frequency). The brief high amplitude oscillations called bursts in the two traces manifest the effect of inhalation by the rat and delivery of a step excitatory input through R in the model. Each burst manifests a state transition at its onset and another at its offset, as the system leaves and returns to its basal chaotic state. A good analogy is the way that a laser jumps from a disordered low energy state into a highly coherent state under activation. As the new state takes hold, it enslaves the activity of all of the bulbar neurons into a common instantaneous frequency of oscillation in their pulse probabilities of firing. The level of arousal controls the steepness of the sigmoid curve (Figure 4) and thereby facilitates destabilization, in which the entire olfactory system jumps from prestimulus control state to an activated state.

****A state transition is a jump of the olfactory system from one attractor to another.****

4. Local and global stabilization of the olfactory system.

4.1. Local homeostatic regulation of bulbar neural activity

A large and complicated system such as that for olfaction must have two types of mechanism to ensure its life-long robustness. One type is homeostatic, operating automatically and locally within the components of the system. The most important mechanism is provided by the thresholds and refractory periods of neurons, which in populations are reflected in the nonlinear gain, the derivative of the sigmoid function (Figure 4). The left, inhibitory end goes to zero gain when the neurons approach or go below their thresholds. The right, excitatory end goes to zero as the neurons are pushed toward the maximal firing rates that they can sustain indefinitely, including time to recover from brief episodes of very rapid firing. In normal function the neurons in olfactory populations very rarely reach the asymptotes, zero and Q_m (Freeman 1992). The P population stabilizes to the right of the crest of the gain curve, indicating that the local population is governed by a nonzero point attractor. Excitatory input reduces the interactive gain in the population, causing it to decrease its output and return to the set point specified by its attractor. Inhibitory input increases the feedback gain in the population, causing it to increase its output level to its set point (Freeman 1975). The M-G populations stabilize to the left of the crest of the gain curve, which indicates that the local attractor is a limit cycle. Inhibitory input tends to suppress the oscillation, whereas excitatory input tends to enhance it by increasing the internal feedback gain. If the excitatory input is sufficient, the increase in gain with increase in activity causes a regenerative increase, so that the system becomes unstable, and undergoes a

state transition from a basal state to a burst state (Figure 7). The burst state is stable as long as the input excitation is maintained; the system returns to its basal state when the input is terminated.

****Neural feedback mechanisms establish attractors that, by definition, are stable.****

4.2. Automatic volume control for stabilization with respect to input.

Another autoregulatory property is manifested in the P population, which by interactions within the neighborhood of the glomeruli stabilizes the OB in respect to excessive input. For study of the operation of dynamic range compression at the input stage to the OB, an electrical test shock, $r(t)$, is given to axons in the primary olfactory nerve axons by electrical stimulation, and the number of action potentials is measured of P and M cells in response to the stimulus. In paired-shock testing a conditioning electrical stimulus, $r(t - T)$, is given at various times, T , before the test shock. The conditioning stimulus to the PON (but not the LOT) elicits long-lasting attenuation of the responses to the test stimulus, $r(t)$, and the amount of attenuation depends on the magnitude of the activity evoked by the conditioning stimulus. That is, the attenuation operator depends on the output $p(t)$ of the bulbar neurons and not on the PON input $r(t)$ directly. The generic function,

$$p(t) = r(t) \exp[-P(t) t], \quad (5)$$

has the form described by Rushton for light adaptation in the retina: logarithmic compression of the input range, and the normalization of neighboring input, so as to conserve spatial patterns of input despite the wide range of variation in the numbers of axons carrying the input.

****Dynamic range compression gives automatic volume control to stabilize the OB.****

Attenuation is a form of presynaptic inhibition (Freeman 1975), and there is evidence suggesting that its cellular basis is a transfer of chloride ions (Siklós et al. 1995) from within P cells and intraglomerular M dendrites into the extracellular tissue compartment, thereby reducing the effectiveness of the GABAergic P cells in proportion to the amplitude of their activity. Attenuation is reversibly blocked by reducing blood flow at the bulbar surface, showing that it is a controlled, metabolically supported regulatory operation, not mere fatigue or blocking by saturation.

4.3. Centrifugal regulation of the olfactory system.

Controls are maintained on olfaction by the dozen or more pathways from the basal forebrain that send neuromodulatory axons into all parts of the system, but particularly into the AON. The neurochemicals include the five neuroamines (histamine, norepinephrine, dopamine, serotonin, acetylcholine), several amino acids, and an unknown number of neuropeptides. Their functions are poorly understood. An important example is histamine, which is hypothesized to mediate arousal in fear, rage, hunger, etc.

****Forebrain commands are neurochemical for "on", "off", "learn", "dishabituate", etc.****

5. Macroscopic olfactory function relating to behavior.

5.1. Temporal and spatial ensemble averages.

To understand the work of the OB it is essential to review the two hierarchical levels of neural activity in the brain, and the two methods of statistical averaging by which measurements of activity densities are made at these two levels. At the neural level the actions of single neurons are observed in pulse trains and with intracellular transmembrane PSPs. Bulbar and cortical neurons fire erratically in what appears to manifest a Poisson process with a refractory period that is also characteristic of neocortical neurons. Owing to randomness the relation of the activity of a single neuron to a sensory or motor event can only be established by repeating the stimulus or response many trials and averaging the recordings with a time reference point at the onset of the event. This procedure is known as time ensemble averaging.

****Olfactory neural activity is nearly random at the microscopic level.****

Actions of neural populations are observed at single locations with recordings of extracellular multiunit activity or dendritic potentials, which constitutes a local spatial average (Figure 3). A population has a LMF because of the sparse, distributed feedback by which each neuron transmits to roughly 10^3 to 10^4 neurons and receives from equivalent numbers of neurons in its surround. An array of noninteractive neurons such as the olfactory receptors R has no LMF. The macroscopic activities cannot be reduced to or measured with the microscopic observations of single neurons, because the fraction of the variance in the single neuron pulse train that is covariant with the LMF is only 0.1% of the total individual variance (Freeman 1975). Such single traces also appear to be random, with amplitude histograms that are nearly Gaussian, and with aperiodic wave forms that give broad power spectra on Fourier decomposition. An activity density function of a collection of LMFs cannot be identified from a single trace, but by spatial ensemble averaging of traces from an array of electrodes, simultaneously in time over the spatial array.

****Neural interactions give rise to macroscopic local mean fields (LMFs).****

As a general rule, and with exceptions, a time ensemble average accesses neural activity in the wave or pulse mode at the microscopic level, and it reveals the relaxation of a neuron or cortical neural network after it has been perturbed by a stimulus and is allowed to relax to its control state. The action potentials from receptors provide microscopic input to the OB, from which emerges a macroscopic pattern of activity over the entire OB (Figure 8). A spatial ensemble average represents the neural activity in either the pulse or wave mode and thereby reveals the macroscopic space-time patterns of neural populations. That pattern is then re-expressed in microscopic action potentials carried to the PC by M axons, where again it triggers the construction of a macroscopic pattern by the entire PC. These operations between levels constitute the principle work of the OB and PC in olfaction.

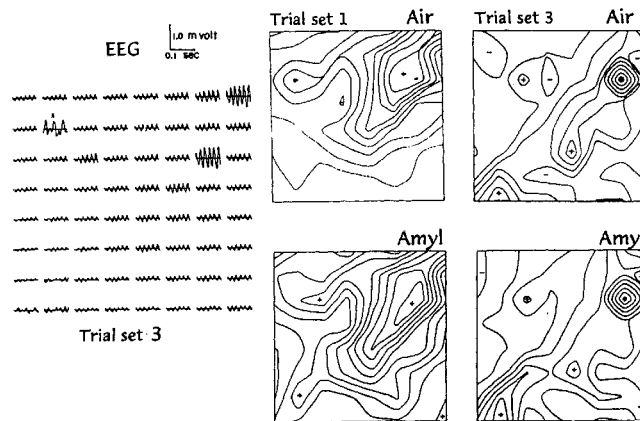

Figure 8. Multichannel recording with an 8x8 array of a representative OB burst from a trained rabbit, showing the common carrier wave and its spatial amplitude modulation (AM). Time: 100 msec. Amplitude ± 400 microvolts. Frames at right show contour plots of the root mean square amplitude patterns in the control and odorant-stimulated states in the first and third of weekly training sessions. The AM patterns typically lacked invariance with respect to the odorant input. The phase modulation (PM) is too small to be seen with the naked eye. It is measured by the Fourier transform. From Freeman and Schneider (1982)

Time ensemble averaging is not useful for deriving endogenous responses of the OB to odors, because the neural populations are not stationary. The OB undergoes state transitions regularly with each inhalation and exhalation, at rates from $<1/\text{min}$ to $>10/\text{sec}$ in various species (Figure 7). An odorant-related burst of EEG activity emerges in the OB with each state transition at unpredictably varying frequencies and times of onset. Time ensemble averaging treats these endogenous components as noise and expunges them. Spatial ensemble averaging over simultaneous recordings from arrays of electrodes properly spaced over a population serves to extract an endogenous pattern that deletes local variations (Freeman 1992).

****Temporal and spatial ensemble averaging extract different aspects of neural activity.****

Spatial ensemble averages in the wave mode by recording extracellular dendritic waves have the advantage of prior spatial averaging over local neighborhoods, provided the electrodes in an array are carefully positioned with respect to the geometry of the fields of electric current. In the appropriately laminar cytoarchitecture of the OB, AON and PC a single trace from the brain surface manifests the averaged activity of roughly 10^4 neurons.

5.2. Identification of odorant related spatial patterns in olfactory EEGs

When a rabbit is trained to discriminate two or more odors of types A, B, C... (Figure 9) and multichannel recordings are made in each of a set of presentations followed by correct identification of each odorant (Figure 8, left), then the measurements on the traces serve to classify them retrospectively into groups corresponding to the correct odorant types. The features in the EEG that correctly serve to classify the traces define the state variables of the OB and its output to the PC.

OB signals are carried by a common wave form that is typically aperiodic.

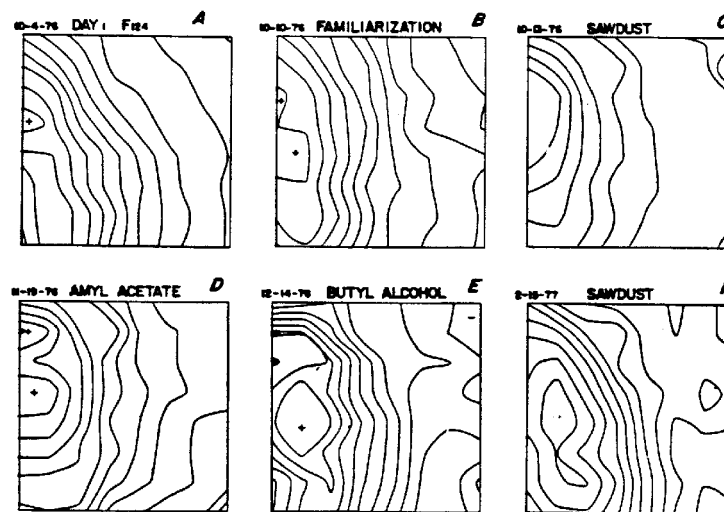

Figure 9. The sequence is shown for a rabbit OB over 20 weeks with serial classical conditioning. When the animal was re-trained (F) to a previous odorant (C) the spatial pattern of AM did not revert to its previous form. From Freeman and Schneider (1982)

Behavioral correlates taken in this way show that odorant information in the rabbit EEG burst exists as a spatial amplitude modulation (AM) of the EEG wave form that is present on all channels in the array, and that comprises 20 - 80% (average: 65%) of the total variance of the measured activity (Freeman 1992). The burst rides on a slow surface-negative wave that manifests mitral and granule cell excitation in response to excitation by receptor and P cells during each inhalation. That slow wave must be filtered out before the AM patterns can be precisely measured. Neither the amplitude of the slow wave nor the spectrum of frequencies of this EEG contribute to classification.

When the spatial AM patterns are plotted in the form of contour plots (Figures 8, 9), they show irregularities in their shapes, which fail to conform to any geometrical pattern, though each rabbit has its uniquely shaped AM figure, like a signature that is easily recognizable, even though it is never twice identical. When the 64 amplitude values from a burst are evaluated on 64 independent coordinates, the spatial pattern is described by a point in 64-space. A collection of bursts from the same subject given the background odorant forms a cloud of points. Its center of gravity or centroid expresses the average spatial pattern or 'signature', and the radius of the cloud given by the standard deviation of the points around the centroid gives the variability of the 'signature'. When the subject is given two odorant types, A and B, randomly alternating on successive trials, the collection of bursts forms two clouds of points with centroids, which express the differences in the spatial patterns. In order to find the centroids, a collection of bursts for each class of odors is divided into two equal and independent sets: a "training set" and a "test set". The training set is used to calculate a centroid for each class. The test sets are then classified by asking whether each point in the A or B test set is closer to the A or B centroid in the training set. The procedure is repeated in the method called cross-validation. The

probability of difference between two 'signature' patterns is given by a t-value: the Euclidean distance between the centroids, divided by the mean standard deviation of the two clouds.

****Spatial patterns of amplitude modulation of the carrier wave are measured in 64-space.****

The classification procedure has been repeatedly applied to the burst data with the progressive removal of channels randomly selected, in order to determine which channels might be more or less important for the correct classification. The goodness of classification decreases in direct proportion to the number of channels removed, but no one channel is any more or less important than any other. This shows that the information density is spatially uniform over the array. Every neuron participates in the discrimination of every odorant, irrespectively of whether it fires rapidly, slowly, or not at all. This inference is fully compatible with the extensive data base on selective responding of single neurons to odors (Wellis, Scott and Harrison 1989), because in pattern formation nonresponding is as important as responding. It is also fully compatible with pattern recognition theory, in which an integral transform of an image, such as the 2-dimensional Fourier transform, serves to de-localize the features of patterns. This is how a hologram, for example, can be broken into pieces, but each piece has the full image, though with reduced resolution. However, it is not compatible with hypotheses holding that the output of OB olfactory information is from localized areas of the OB or small subsets of neurons.

****The density of classificatory information in EEG patterns is spatially uniform.****

When conditioning of a rabbit is undertaken to a novel odorant by pairing it with an unconditioned stimulus, a new pattern emerges with a new centroid, and the locations change for all of the other centroids in 64-space. That is, all of the burst spatial patterns change. The centroid locations change from each recording session to the next, showing that this associative memory system undergoes continual change. The change is irreversible, because when odorant A is re-introduced after conditioning to A, B, C... a new centroid appears and the old one does not recur (Figure 9). Similarly, when the reinforcement is switched between two odors, one rewarded and the other not, the stimuli and the responses are the same, but both odorant patterns change, and so does the control pattern for the background. These results show that the odorant-related patterns are not fixed representations of odors, nor can they be stored, retrieved or matched as such. They are dynamical action patterns (Freeman 1991, 1995).

****Odorant-related EEG patterns are not representations of odors.****

5.4. Signal definition and noise reduction in OB output by LOT divergence

Each M cell axon distributes its axon broadly though not homogeneously over the surfaces of the AON and PC by collaterals and synapses in passing of the LOT. Conversely each nuclear and cortical pyramidal cell that receives LOT input converges integrates pulses from M cells that are broadly distributed over the OB. This divergence/convergence in the LOT (Heimer 1968) contrasts markedly with the topographic projection of the PON (Figure 10) and shows that the LOT serves to perform a spatial integration, prior to the temporal integration done by temporal dispersion in the LOT and by the pyramidal cell dendrites.

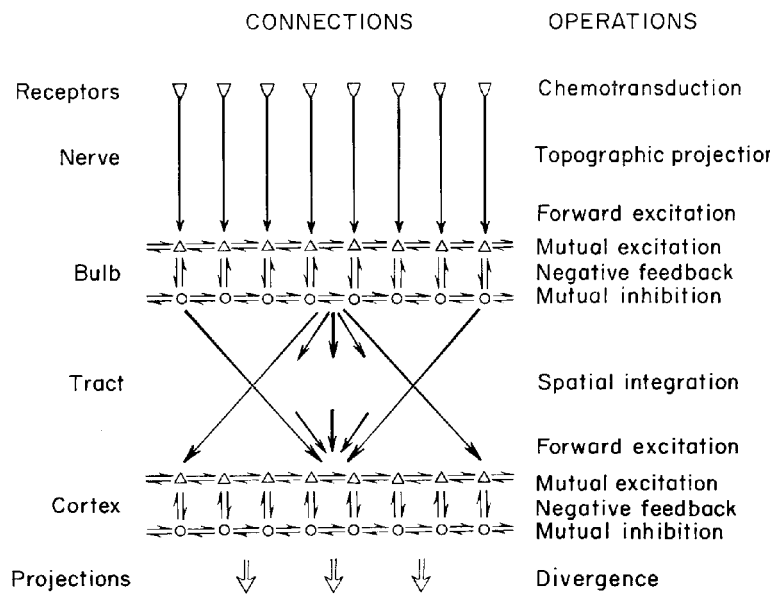

Figure 10. The receptor transmission through the PON to the M cells is topographically organized, whereas the transmission of M cells to the AON and PC through the LOT is divergent from the OB and convergent to the PC, because each A cell receives from a broad width of the OB (Heimer 1968). The resulting spatial integration enhances the OB activity that has the same frequency everywhere, which is the cooperative activity of the OB with its common wave form, defining it as signal, and it cancels the activity that is dispersed in phase and frequency, which is the spatially incoherent, sensory-evoked activity, defining it as noise. In contrast to sensory projections to cortex, the majority of cortico-cortical pathways are divergent/convergent.

This on-line space-time integration by the PC has the property that the only inputs given to the AON and prepyriform by the OB that are summed without smoothing are those that share the common instantaneous frequency of the OB oscillations (Freeman 1991). Other activity is smoothed by dispersions of frequency and phase. The PC has its own characteristic frequency, which facilitates its resonance in the middle range of OB driving. The integral transform defines the OB common EEG wave form (Figure 8) as a carrier wave of a signal, and it attenuates as noise the residual variance (both measured by their mean square amplitudes), giving the signal:noise ratio. The residuals are shown to be noise, because they invariably fail to support classification of EEG segments with respect to odors. This signal extraction operation, a "brain laundry", is important for extracting the 20 - 80% of the activity in the common mode of macroscopic oscillation, but its major role is to extract the signal from the pulse trains of mitral cells. The fact that ~ 20 minutes of sampling typical pulse trains is required to demonstrate their global temporal structure, suggests that the macroscopic:microscopic S:N ratio of single cells is as low as 10^{-4} .

Divergence of the LOT extracts the OB signal to be received by the PC.

5.5. Modifiable synaptic gains with associative learning and habituation.

The capability of the central olfactory system to respond selectively to odors is clearly dependent on learning, because the synaptic changes induced by the training process enhance the sensitivity to foreground odorant activation and diminish the sensitivity to the background. The sites of the synaptic changes that occur with conditioning to stimuli have been determined by use of electrical stimulation of the LOT with implanted electrodes in animals that were trained to respond to the electrical stimulus used as a conditioned signal or to habituate to it (Freeman 1975). Analysis and simulation of the monosynaptically evoked potentials, which were recorded from the OB and PC, have shown that the synapses that undergo irreversible modification in associative learning are those of axon collaterals by which M cells excite each other, and by which superficial pyramidal cells in the PC excite each other. They are not the synapses of PON axons onto M cells, of M cells onto G cells, nor are they the synapses of LOT axons onto PC cells, at which LTP has been demonstrated. These M-M synaptic changes in the OB under classical aversive reinforcement require the release of norepinephrine into the OB by centrifugal axons coming from the locus coeruleus (Gray et al. 1986), an example of centrifugal control in the associative learning process.

****Associative learning is by enhancement of mutually excitatory M-M synapses.****

Associative learning is designed to enhance responses to stimuli that are made important by reinforcement. Equally important is habituation to attenuate responses to stimuli that are trivial, confusing or disruptive. It is central and not to be confused with adaptation in receptors. Habituation is automatic and progressive in the absence of reinforcement, as shown by the fact that it occurs in the surgically isolated OB even more rapidly than in the intact OB. Whereas learning is irreversible and dependent on correlated activity of pairs of neurons at excitatory synapses, habituation is reversible, dependent only on the stimulus-evoked activity of individual neurons. It takes place at the synapses of the excitatory neurons onto both inhibitory and other excitatory neurons (Freeman 1992). Discriminative conditioning requires presentations of reinforced and unreinforced stimuli on randomly interspersed trials in the same session, in order that the salient properties of a reinforced stimulus be identified against the infinitely complex background. Maintenance of habituation appears to require metabolic energy, because it can be progressively impaired in long training sessions leading to distractibility and impairment of discrimination. Background stimuli on habituated synapses are not lost. Whereas the spectral energy of oscillations in response to learned stimuli is enhanced in the within-burst gamma frequency range, the spectral energy of oscillations in response to habituated stimuli is shifted into the between-burst theta band. Thereby the unwanted stimuli in the background enhance responses to desired stimuli, because they contribute to the excitatory shift that increases the nonlinear gain and facilitates the input-dependent state transition.

****Habituation, an essential part of discrimination of sensory stimuli, occurs in the OB.****

5.6. A neural mechanism for generalization.

According to the Hebb postulate the synapses in the OB between pairs of M cells are strengthened when they are simultaneously excited by an odorant. Over a series of sniffs the co-excited M cells cumulatively form a nerve cell assembly for that odorant. Owing to the randomness of input to the large number of receptors for each odorant, a nerve cell assembly

may comprise a substantial number of M cells over the several hundred sniffs that typically constitute a training session. The nerve cell assembly can account for generalization over equivalent receptors, because once it is formed, the entire collection of M cells belonging to the nerve cell assembly tends to be activated by mutual excitation when any subset receives input. Mutual excitation in conjunction with the sigmoid curve accounts for enhanced sensitivity in respect to the learned odorant, because when any one M cell in the nerve cell assembly receives input, it excites other M cells in the assembly over strengthened lines, and these in return re-excite it, driving it toward the peak of its nonlinear gain curve. The input-dependent increase in gain for all M cells in the assembly leads to explosive increases in activity and in gain, which can be directly attributed to the regenerative voltage-dependent sodium conductance increase in the trigger zones of the M cells (Freeman 1992).

****The Hebbian nerve cell assembly serves generalization over equivalent receptors.****

This is the first of two stages in classification. The second stage occurs when the OB is destabilized and transits into a new basin of attraction. Basins also have the property of generalization, because the system tends toward the attractor irrespective of starting location in the basin. The nerve cell assembly by its explosive activation is the critical determinant in the selection of a basin by the input. The 1st stage ignites the cell assembly; the 2nd stage ignites the entire OB.

5.7. Preamerent limbic modulation of olfactory system state transitions.

The prior formation by past experience of the landscape formed of the basins of attraction appears to be subject to modulation by the rest of the forebrain, particularly by the EC in the limbic system, in the processes of preamere and attention (Kay et al. 1996). The OB at all times is in a prepared state from prior experience that is stored in the altered connectivities of multiple nerve cell assemblies within the population of mitral cells. These nerve cell assemblies establish the potentiality for multiple trajectories in the phase space of the olfactory system, which is the dynamic space of all possible spatiotemporal patterns. Only one pattern can be realized at a time, but the others are latent and constitute possible stable orbits of activity. Together they configure a global chaotic attractor in the olfactory phase space. This attractor can be conceived as composed of lobes or wings (analogous to the butterfly shape of the Lorenz attractor), each wing corresponding to a learned class of odorant, or to the control odorant condition, or to the control state with exhalation. Each wing is accessed by input to a nerve cell assembly that was formed during training with odorant presentations under reinforcement. The input places the system in a basin of attraction for the wing when the input contains activity on axons within the established nerve cell assembly. Orbiting in a basin reflects the constraint of the trajectory within the wing, and the constraint is expressed as a spatial pattern of amplitude of the common cooperative activity of the neurons comprising the OB. The transition to the basin constitutes the selection and classification of the inhaled odorant. It takes place within the first quarter cycle of the burst oscillation, and the read-out lasts throughout the burst for 50 to 100 msec.

****Discrimination may occur by confinement to a wing of a chaotic attractor.****

Modification of the global attractor is by bifurcation, in which the bifurcation parameter is a synaptic connection strength or the Q_m of the sigmoid curve. Input-dependent state transitions have no change in structural parameters. When an odorant is presented under reinforcement, a new wing is added, which slightly changes all of the other wings. Thereafter, access to the wing is induced by the concomitance of three conditions: a state of arousal expressed in a steep sigmoid curve; a nerve cell assembly for the stimulus; and a global volley of input during an inhalation that includes receptor discharge directed into the nerve cell assembly. The input volley broadly excites the OB and increases its internal feedback gains. This is similar to lowering the temperature of a

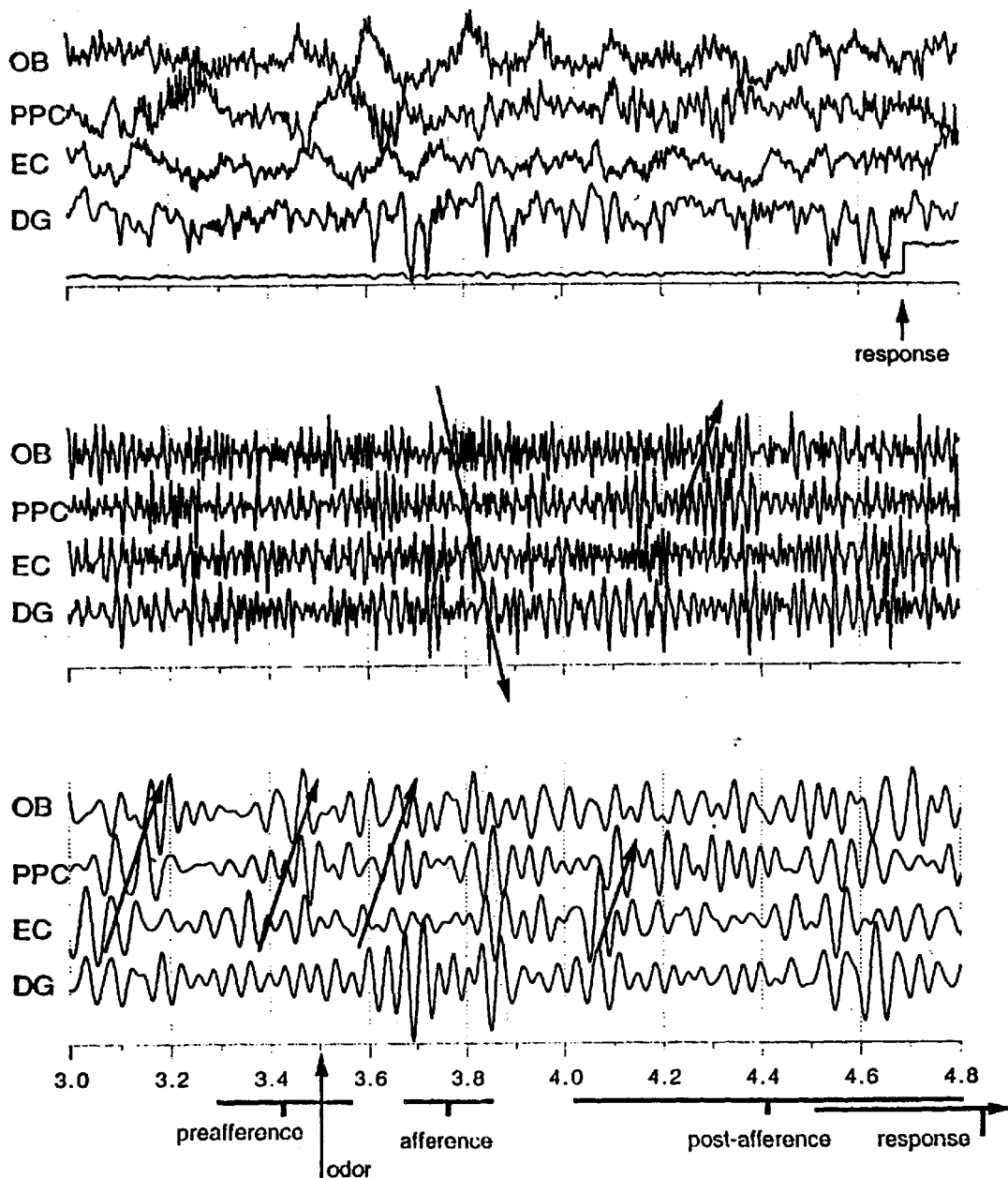

Figure 11. Upper frame shows wide band EEG traces including the theta band (3-9 Hz) from OB, PC, EC, dentate gyrus of the hippocampus, and a marker for bar press in response to an odorant stimulus. Middle frame shows activity in the gamma band (35-100 Hz in the rat) with bursts between OB and PC. Lower frame shows beta band (10-35 Hz) bursts from EC to OB and PC. Arrows indicate the directions of transmission. The bars below the time base (in seconds) indicate the average center time and standard deviation of duration of EC bursts labelled preafferent and postafferent, bracketing the afferent burst from the OB to the PC and EC. There is substantial variation between trials. The data show that the olfactory and limbic system communicate frequently with short bursts in both directions during an odorant identification and classification process. From Kay et al. (1996).

liquid to freeze it. The "freezing" is manifested in the burst that is more highly ordered than the interburst state. As the OB is brought to its point of transition, it becomes supersensitive, so that the nerve cell assembly can make the choice (Freeman 1992). The prepyriform dynamics may have its own global chaotic attractor with multiple wings, and one or more patterns of input from the OB can direct it into the basin of a wing. The state transition of the PC mechanism constitutes the readout of the OB classification as a next step to a behavioral response selection.

EEGs have recently been recorded simultaneously from the OB, PC, EC and hippocampus in rats trained to bar press on receipt of odorant stimuli. Analysis has shown that activity occurs in three main frequency bands: the gamma band (35-100 Hz) in which transmissions from OB to PC and EC are concentrated, the theta band (3-9 Hz) in which respiratory gating occurs, and the beta band (10-35 Hz) in which centrifugal transmissions occur from EC to PC and OB (Bressler 1988; Kay et al. 1996). The search for correlations between brief EEG segments from these structures, making allowance for the conduction distances and delays between them as measured by use of electrically evoked potentials, has yielded evidence for extensive but intermittent communication among these parts (Figure 11). The events appear to last on the order of 50 to 75 msec, and to recur at unpredictable times and rates. Of particular interest are rapid sequences of limbic transmissions into the OB that occur just prior to the onset of an odorant M, in a training schedule that has a fixed intertrial interval of 6 sec, so that the subjects could predict the time of onset of the next stimulus. A brief beta band transmission from EC to PC preceded a PC burst in the gamma range a few hundred msec prior to the onset of the conditioned response. These findings are evidence for the active participation of the limbic system in all phases of searching and consummatory behavior.

****The OB, PC, and EC rapidly exchange messages during odorant identification.****

6. Conclusions.

6.1. The rationale for constructions versus representations.

Emphasis has been placed in this review on the difficulty faced by the olfactory system of classifying faint traces of odors that are behaviorally relevant, in the circumstance of the infinite complexity and variety of the chemical environment. The biological mechanisms that have evolved include a vast array of broadly tuned receptors, synaptic mechanisms for shaping

connections of central neurons to form nerve cell assemblies, formation of a macroscopic global attractor with multiple wings, each of which can be accessed by state transitions of the olfactory neural populations, and a spatiotemporal integral transform of the output by the LOT-PC that enhances the attractor output and expunges the residues of the sensory-evoked local activity in the OB. Thereby the forebrain receives only the constructs of the OB and not the raw sense data. Why should this be? It is because the environment is infinitely complex, with no fixed objects, features, logical trees of classes, or patterns that can be "completed". Those concepts are essential for representations, which can be taken in, stored, retrieved, and matched with new inputs. The OB has no mechanisms to support them. The nature and significance of "objects" are decided by the limbic system, which can change the basin landscape in rapid sequential steps. The olfactory system is one of the tools used by the limbic mechanisms of intentional behavior, by which goals are set, and information is sought and interpreted in order to achieve them (Freeman 1995).

****Brain activity is not representational; it is intentional.****

6.2. Potential applications and future directions in pattern classification.

While at first glance olfaction might appear to be unique in this respect, the visual, auditory and somatic worlds are equally complex, and their patterns of operation are similar to those in olfaction (Barrie et al. 1996). The study of olfaction can make important contributions to the understanding of other sensory systems, and to the design of artificial intelligence that can interact effectively with the real world. The concepts and methods of nonlinear dynamics have provided a basis for design of experiments, interpretation of data, and simulation of the chaotic time series of the central olfactory system with the solutions of nonlinear ODEs. Spatial pattern formation is the primary task of the olfactory receptor layer, and pattern classification and interpretation are the primary tasks of the central olfactory system. The parallel distributed nonlinear feedback model that is described here, operating in the chaotic domain, has been shown to perform pattern classification of industrial data (Davis and Eichenbaum 1991; Yao, et al. 1991). It can learn a new class of inputs in one or a few trials lasting 200 msec of simulated time, and it is virtually immune to background noise. The most useful application for this biologically inspired system may be to provide an interface between the real world and finite state automata, in the way that the sensory cortices interface between the environment and the limbic system.

****Brains are finite; the world is infinitely complex.****

Four directions appear for future studies. 1. The controls by the neuromodulators on the performance of the olfactory system should be investigated in more detail, particularly the roles of acetylcholine and norepinephrine in learning, of dopamine in reward, of histamine in arousal, and of oxytocin and vasopressin in emotional responses. 2. The structure of preafferent messages from the EC, and the nature of their actions in modulating the landscape of the basins of attraction, call for systematic analyses. 3. The noise-stabilized chaotic dynamics in pattern classification systems must be tamed and put to commercial uses. 4. The neurodynamics that is developed to describe the mechanisms found in the olfactory system should be applied to the

study of other sensory systems, after appropriate modifications have been made to adapt it to the special conditions and constraints that hold for those systems.

Acknowledgements

Support for this work was provided by the National Institute of Mental Health, and by the Office of Naval Research. Some text was adapted from Chapter 9 in: Davis and Eichenbaum (1991).

General References

Davis JL, Eichenbaum HB (eds.) Olfaction: A Model System for Computational Neuroscience. Cambridge MA: MIT Press.

Freeman WJ (1975) Mass Action in the Nervous System. New York: Academic Press.

Freeman WJ (1991) The physiology of perception. *Scientific American* 264: 78-85.

Freeman WJ (1995) Societies of Brains. A Study in the Neuroscience of Love and Hate. Hillsdale NJ: Lawrence Erlbaum Associates.

Shepherd GM (1994) Synaptic Organization of the Brain (3rd ed.). Oxford UK: Oxford University Press.

Shipley MT, Ennis M (1996) Functional organization of olfactory system. *Journal of Neurobiology* 30: 123-176.

References Cited

Barrie JM, Freeman WJ, Lenhart M (1996) Modulation by discriminative training of spatial patterns of gamma EEG amplitude and phase in neocortex of rabbits. *Journal of Neurophysiology* 76: 520-539.

Bressler SL (1988) Changes in electrical activity of rabbit olfactory bulb and cortex to conditioned odorant stimulation. *Journal of Neurophysiology* 102: 740-747.

Freeman WJ (1972a) Measurement of open-loop responses to electrical stimulation in olfactory bulb of cat. *Journal of Neurophysiology* 35: 745-761.

Freeman WJ (1972b) Waves, pulses and the theory of neural masses. *Progress in Theoretical Biology* 2: 87-165.

Freeman WJ (1992) Tutorial in neurobiology: From single neurons to brain chaos. *International Journal of Bifurcation and Chaos* 2: 451-482.

Freeman WJ, Schneider W (1982) Changes in spatial patterns of rabbit olfactory EEG with conditioning to odors. *Psychophysiology* 19: 44-56.

- Gray CM, Freeman WJ, Skinner JE (1986) Chemical dependencies of learning in the rabbit olfactory bulb: acquisition of the transient spatial-pattern change depends on norepinephrine. *Behavioral Neuroscience* 100: 585-596.
- Heimer L (1968) Synaptic distributions of centripetal and centrifugal nerve fibres in the olfactory system of the rat. An experimental anatomical study. *Journal of Anatomy* 103: 413-432.
- Herrick CJ (1948) *The Brain of the Tiger Salamander*. Chicago: University of Chicago Press.
- Kay LM, Freeman WJ, Lancaster LR Jr.. (1996) Simultaneous EEG recordings from olfactory and limbic brain structures: Limbic markers during olfactory perception. Chapter in: *Advances in Processing and Pattern Analysis of Biological Signals*. Gath I, Inbar G (eds.), New York: Plenum, pp 71-84.
- Kay LM, Shimoide K, Freeman WJ (1995) Comparison of EEG time series from rat olfactory system with model composed of nonlinear coupled oscillators. *International Journal of Bifurcation and Chaos* 5: 849-858.
- Siklós L, Rickmann M, Joó F, Freeman WJ, Wolff JR (1995) Chloride is preferentially accumulated in a subpopulation of dendrites and periglomerular cells of the main olfactory bulb in adult rats. *Neuroscience* 64: 165-172.
- Skarda CA, Freeman WJ (1987) How brains make chaos to make sense of the world. *Behavioral and Brain Science* 10: 161-195.
- Sullivan SL, Dryer L (1996) Information processing in mammalian olfactory system. *Journal of Neurobiology* 30: 20-36.
- Wellis DP, Scott JW, Harrison TA (1989) Discrimination among odorants by single neurons of the rat olfactory bulb. *Journal of Neurophysiology* 61: 1161-1177.
- Yao, Y., Freeman, W.J., Burke, B. and Yang, Q. (1991) Pattern recognition by a distributed neural network: an industrial application. *Neural Networks* 4: 103-121.